

# MANUFACTURER-SPECIFIC RETURN CRITERIA



## BPW Hub Unit

### Criteria:

Identification

Completeness

Mechanical damage

Corrosion

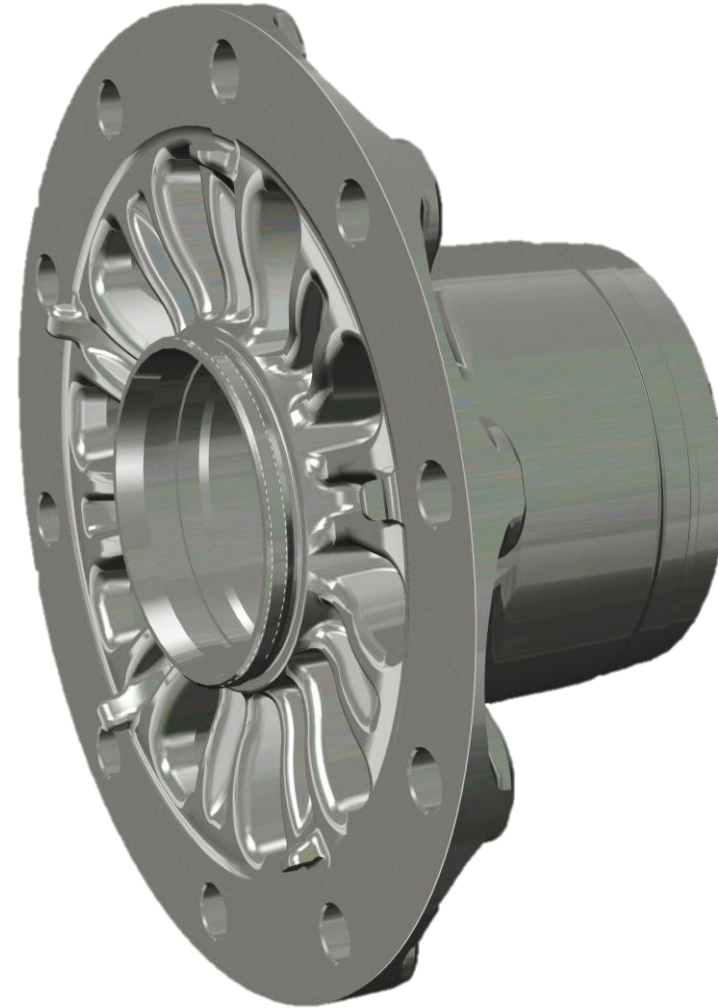

# MANUFACTURER-SPECIFIC RETURN CRITERIA



## BPW Hub Unit

### Criteria:

Identification

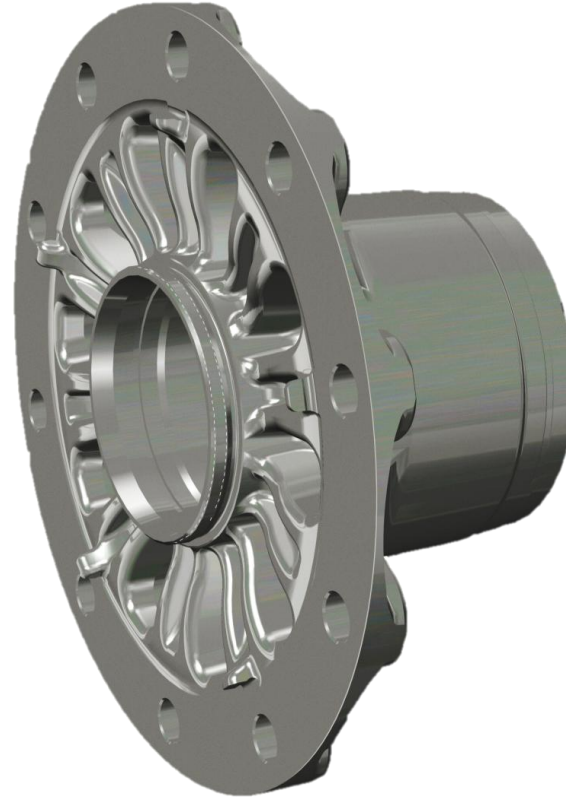

Acceptable



Acceptable

# MANUFACTURER-SPECIFIC RETURN CRITERIA



## BPW Hub Unit

### Criteria:

Completeness

Existing and installed capsule preferred



Acceptable

# MANUFACTURER-SPECIFIC RETURN CRITERIA



## BPW Hub Unit

### Criteria:

Completeness

(Partially) disassembled hubs are not acceptable



Not acceptable



Acceptable

# MANUFACTURER-SPECIFIC RETURN CRITERIA



## BPW Hub Unit

### Criteria:

Completeness

Dismantled brake discs and wheel studs are preferred

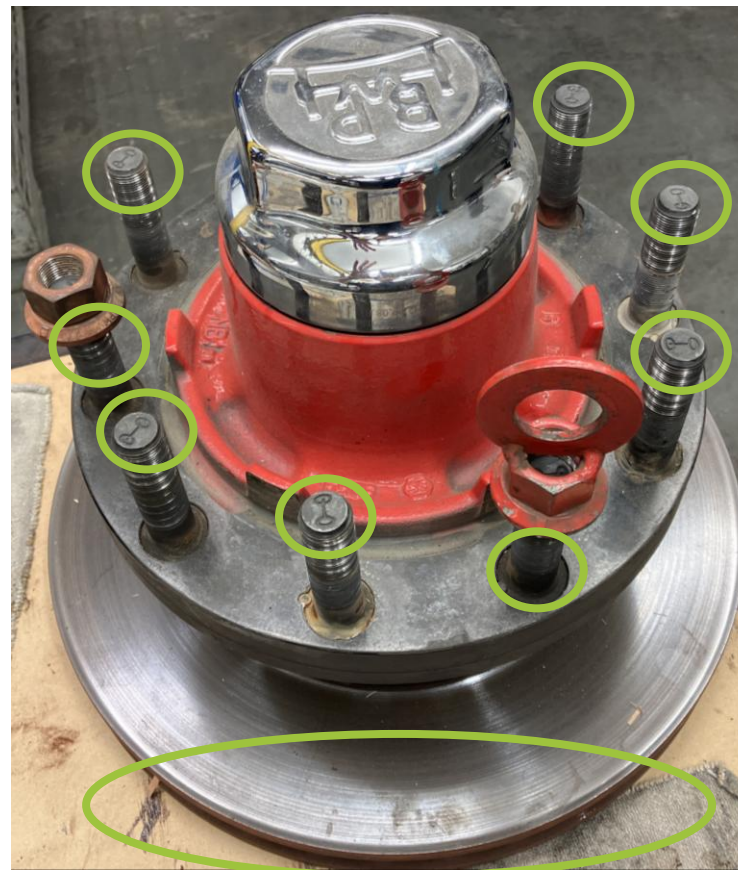

Acceptable



Acceptable

# MANUFACTURER-SPECIFIC RETURN CRITERIA



## BPW Hub Unit

### Criteria:

Mechanical damage

Breaks in the wheel centering are not acceptable



Not acceptable

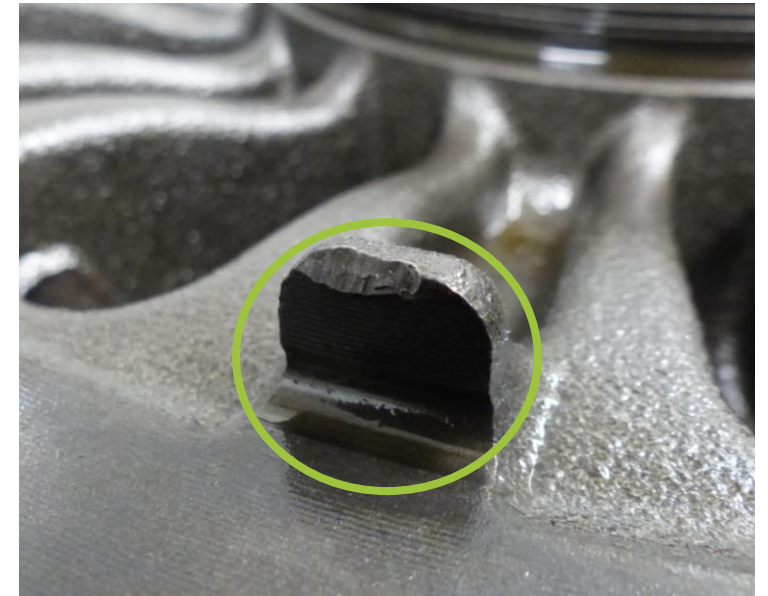

Acceptable

# MANUFACTURER-SPECIFIC RETURN CRITERIA



## BPW Hub Unit

### Criteria:

Mechanical damage

Breaks in the wheel centering are not acceptable



Acceptable



Acceptable

# MANUFACTURER-SPECIFIC RETURN CRITERIA



## BPW Hub Unit

### Criteria:

Mechanical damage

Indentations on wheel stud bores are acceptable



Acceptable

# MANUFACTURER-SPECIFIC RETURN CRITERIA



## BPW Hub Unit

### Criteria:

Mechanical damage

Slight quirks are acceptable



Acceptable

# MANUFACTURER-SPECIFIC RETURN CRITERIA



## BPW Hub Unit

### Criteria:

Mechanical damage

Slight quirks are acceptable.



Acceptable



Acceptable

# MANUFACTURER-SPECIFIC RETURN CRITERIA



## BPW Hub Unit

### Criteria:

Mechanical damage

Severe damages are not acceptable



Not acceptable



Not acceptable

# MANUFACTURER-SPECIFIC RETURN CRITERIA



## BPW Hub Unit

### Criteria:

Corrosion

Corrosion outside is acceptable



Acceptable



Acceptable

„Components without existing bearing“ – see slide 4.

# MANUFACTURER-SPECIFIC RETURN CRITERIA



## BPW Hub Unit

### Criteria:

Corrosion

Inner surfaces free from corrosion. Brownish grease is acceptable, flash rust on the retaining ring is acceptable



Acceptable



Acceptable

# MANUFACTURER-SPECIFIC RETURN CRITERIA



## BPW Hub Unit

### Additional information:

Only genuine BPW Hub Units are acceptable

Non-BPW Hub Units or Hub Units remanufactured/repaired by third-parties are not acceptable